

P & I for PRESSURECHECK Single Fire Pump

LEGEND
 L: Signifies Monitored Valves
 S: Signifies Non-Monitored Valves
 PS1 Fire Pump.
 PS2 Fire Pump.
 PS3 Jockey Pump.
 PS4 Fire Pump Running
 FS1 System Operated Flowswitch
 * Pressure Gauges

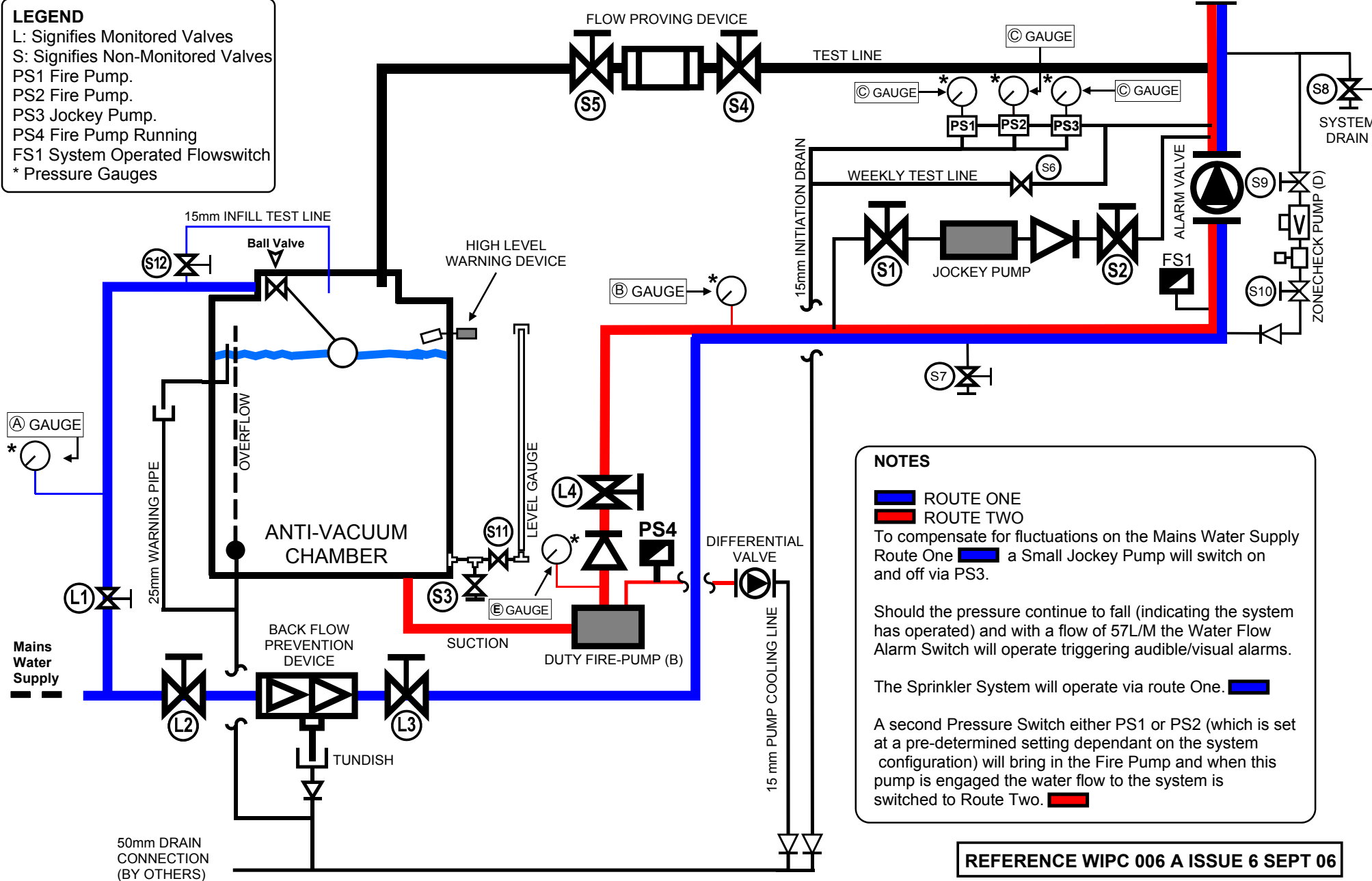

NOTES

- █ ROUTE ONE
- █ ROUTE TWO

To compensate for fluctuations on the Mains Water Supply Route One █ a Small Jockey Pump will switch on and off via PS3.

Should the pressure continue to fall (indicating the system has operated) and with a flow of 57L/M the Water Flow Alarm Switch will operate triggering audible/visual alarms.

The Sprinkler System will operate via route One. █

A second Pressure Switch either PS1 or PS2 (which is set at a pre-determined setting dependant on the system configuration) will bring in the Fire Pump and when this pump is engaged the water flow to the system is switched to Route Two. █